

## Temperature Sensor TS-1-A-120-3/8"

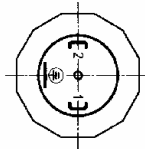

Pin 1 = Out / GND  
Pin 2 = +Vcc

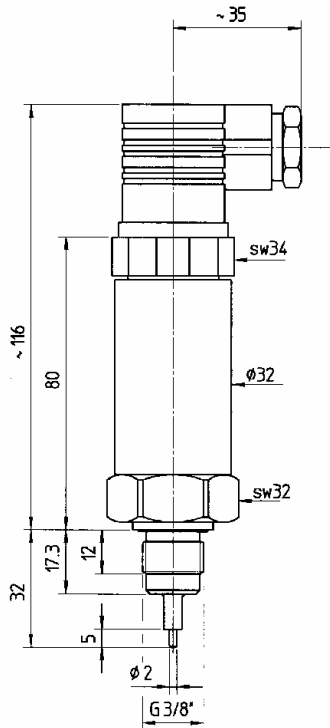
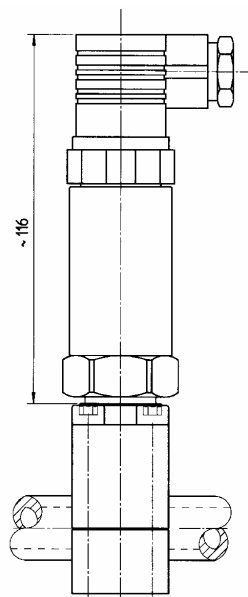

- ◆ Temperature sensor Type L thermocouple
- ◆ Temperature range -30 ... +120 °C
- ◆ Output 4 ... 20 mA / 2 wires
- ◆ Protection mode IP 65
- ◆ Right-angle plug connection DIN43650 A
- ◆ Robust stainless steel housing

### Description

In all industries, sheathed (mineral-insulated) thermocouples are increasingly used for temperature measurement applications. Compared to other thermocouples and resistance thermometers, they respond to temperature changes more quickly and are smaller in size, which makes it possible to use them in constricted areas and places that are difficult to access. In addition, they are shock-resistant, pressure-resistant and excel by their long durability.

The temperature sensor **TS-1-A-120-3/8"** can be used for direct temperature measurements inside pipes such as hydraulic and lubricating oil pipes. In addition to its robust and compact design, it stands out by its high accuracy and its extensive measurement range. As a standard, the housing and all parts exposed to the liquid are made of stainless steel (Type 1.4571). Soft seals consist of Viton.

Typical fields of application include systems and plant engineering, automation, air conditioning, and refrigeration.

### Installation with serv-Clip 2

The patented measuring connector **sc-2-...** was developed for installation on pressureless hydraulic pipes.

After installation, the measuring connection can continuously be used, supporting operating pressures of up to 630 bar.

The measuring connection **sc-2-...** comes pre-mounted, including measurement coupling and needle. By screwing the measurement coupling onto the pipe, a specially shaped needle is pressed through the pipe wall. Afterwards the measurement coupling is unscrewed again.

In the next step, the temperature sensor can be screwed into the **serv-Clip**. The measuring connection is completely tight and is ready for continuous use.

Using the **serv-Clip® sc-2-...**, the temperature sensor can be installed easily, quickly and safely even by non-technical staff. The whole process takes a few minutes only. No special tools are required for the installation of the **serv-Clip** and the temperature sensor.

The system is completely tight, preventing any contamination of the hydraulic oil and ensuring sustained operational safety. The measuring connections are continuously available for measurement applications.

### Specifications

Temperature range	-30 ... +120 °C
Accuracy	+/- 2 K
Repeatability	Better than 1 K
Pressure range	Up to P <sub>B</sub> 630 bar
Output signal	4 ... 20 mA
Power supply	15 ... 30 V DC, protected against reverse connection
Configuration	2 wires
Protection mode	IP 65
Linearity	0.2 % typ. / max. 0.5 %
Threaded coupling	G3/8" male
Electrical connection	Right-angle plug connection Type DIN 43650 A